

**TRUSSARDI**  
CASA

2024: The Collection



## TRUSSARDI FASHION'S NEW CORPORATE STRUCTURE

Trussardi (fashion) has recently joined the **Miroglio Group**, an international womenswear and retail company with a strong Italian heritage.

The acquisition is part of a restructuring process initiated by the Milanese fashion company with *the aim of strenghtenig the brand* and ensuring the continuity of its industrial operations.

Trussardi joins the Miroglio Group as an independent brand, maintaining its headquarters in Milan.

The Group's strategy is to enhance the Trussardi brand, starting with its distinctive categories (including leather goods). The aim is to develop and strenghten the brand across the board and beyond the boundaries of fashion, offering products and services which reflect its essence in the *lifestyle* world as well.

In this context Trussardi Casa is an essential strategic element, as it continues to express the modern versatility and elegance that have always characterised the Brand.

Trussardi will pursue a multi-channel strategy with a focus on the key markets of Italy, Eastern Europe and the Middle East, where the brand is well established.



# 2024 COLLECTION

**TRUSSARDI**  
CASA

During this year's Design Week, Trussardi Casa will present its collection at the *temporary store* on via Santa Cecilia.

The brand has continued to follow the trend of the last few years with a great deal of consistency and continuity, becoming even more intimate, emotional and tactile. This is expressed through a sleek and versatile furniture collection that is suitable for a wide range of spaces and architectural styles worldwide.

Quality, elegance and refined simplicity continue to characterise Trussardi Casa, as does the search for new talents to interpret the brand's codes, alongside its historic collaboration with **Carlo Colombo**. Thus, **Francesca Lanzavecchia's** classic refinement meets **Jimmy Delatour's** creative flair, **Leonardo Talarico's** rigorous style approaches **Matteo Agati's** soft, sensual forms and **Antonio Facco's** essential elegance. This year, they are joined by newcomer **Silvio Pompei**.

Designers from different backgrounds, cultures and traditions that are nonetheless united by a strong sense of discipline and spontaneous creativity. Each one of them, with their own specific characteristics, contributes to the development of a *shared Trussardi Casa project*.

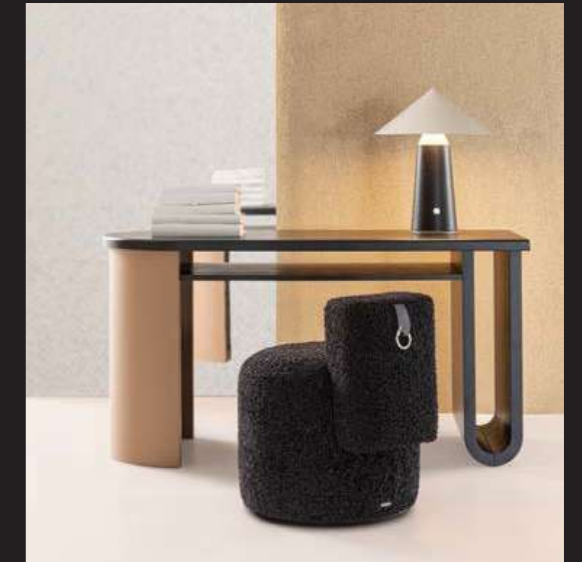

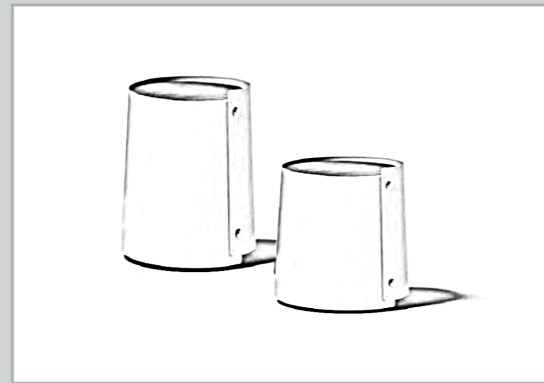

TRUSSARDI CASA\_Sunset Armchair \_2023



TRUSSARDI CASA\_Fence Armchair\_2022



Marangoni\_2020\_Ghirigoro Chaise Longue



Cappellini\_Robs+Osservatorio



Cappellini\_Marangoni\_2015



Silvio Pompei is an Italian designer and a graduate from the faculty of Architecture and Design in Camerino, where he developed a strong sense of ethical and responsible design.

After working in architecture firms and innovative start-ups, he won a scholarship sponsored by Giulio Cappellini. He then went on to enrol at Mater Istituto Marangoni, specialising in furniture and product design.

Silvio's work seeks to challenge the truths of everyday life in search of new means of expression and unexplored potential. He loves simple objects that elegantly combine functionality and use.

Silvio Pompei joined the product and furniture team of Paola Navone's OTTO Studio in 2021, and is a member of the Prisma Marangoni group.

In 2020 he won the "Circular Economy. Essential Furniture" competition with the "Ghirigoro" chaise longue, and the 2022 Nava Design competition with the "Pocket II" rucksack. In 2022 he also won the MM Awards with "Ghirigoro" and was awarded the Silver Prize with "Clutch".

Matteo Agati graduated from Milan Polytechnic – where he won his first Ducati Energia award – with a degree in industrial design and a specialisation in Design & Engineering.

His distinctive artistic trait merges design and decoration, harmoniously balancing innovation and style. "Multidisciplinary hybridisation" are his key words.

Matteo was also presented with a great opportunity to take part in the Master of Italian Product Design at Istituto Marangoni, winning first prize at the "Sit Down!" contest with his "Pagh" project, in partnership with Cappellini. That marked the start of his ongoing collaboration as a freelance professional that continues to this day.

His Hyperethereal Eyeglasses project won him first prize at RADO Star Prize Italy in 2016. He also received first prize for his "me2 vases" project at the "Elle Decor + TID, The Interior Design contest".



Born in the heart of Brianza in 1967, Carlo Colombo graduated in architecture at Milan Polytechnic and works as a design and interior design architect with leading brands: Cappellini, Moroso, Poliform, Varenna, De Padova, Poltrona Frau, Flexform, Artemide, Zanotta and many others. Among his most important awards are:

- 2004 Design of the Year (Tokyo) • 2006 Elle Deco International Awards (Speed cabinets for Zanotta)
- 2010 Elle Deco International Awards (Air table for Poliform) • 2011 Elle Deco International Awards (Cloud collection for Arflex).

He has been designing for Trussardi Casa since 2014, when the brand was first created, and his contribution was crucial in defining the brand's core principles, featuring sophisticated design with market needs in mind.

His work is still at the core of the new Trussardi Casa concept that looks to the future whilst retaining the brand's culture and heritage.



TRUSSARDI CASA\_Godwin Sofa\_2023



TRUSSARDI CASA\_Sunset Armchair\_2023



Poliform\_Dune



CONCRETE ABSOLUTION\_Gran table



Giorgetti\_Swing\_2018



STUDIOTWENTYSEVEN\_Dante Armchair



Jimmy Delatour was born in Paris and graduated from the renowned ESAG Penninghen school in 2008.

After graduation he founded Delatour Design Paris, his creative studio involved with different types of projects, encompassing art direction, brand identity, naming, packaging design and graphic design in various sectors: Nike, Orange, Peugeot, Opéra de Paris, and McDonald to name a few.

In 2017, alongside his branding studio, he undertook a more personal project with the creation of a furniture collection for the Paris-based gallery Armel Soyer. The same design criteria inspired his collaboration with other art galleries around the world (USA, France, Italy and Australia), constantly focusing his creativity on sculptural and clean-cut geometric shapes for limited edition products.

In 2022, he met Giulio Cappellini, who introduced him to mass production design. For Trussardi Casa he created a collection of products that best represent his passion for volumes, materials and clear-cut lines.



TRUSSARDI CASA\_Sivert dinig table \_2023



TRUSSARDI CASA\_ Nebula Sofa\_2022



MOGG\_Olo coffe table



Zanotta\_Nena\_2020



CAPPELLINI\_Arya sospensioni



Hermes 2021

Antonio Facco, designer (Milan, 1991). His Milan-based studio has a multidisciplinary approach to the creative process, and develops a vast array of solutions for diverse interior settings. It spans across art direction, residential and retail interior design, product and graphics. Antonio Facco has worked with several international architects, designers and companies such as Antolini, Bolon, Cappellini, AgustaWestland, Mohm, Oblure, Technogym, etc. creating interior décor solutions and displaying at main exhibition fairs worldwide.



Bold, eclectic, unconventional and empathetic. This is Francesca Lanzavecchia's approach to design. Born in Pavia in 1983, she graduated in Industrial Design from Milan Polytechnic. She attended a master's course in Conceptual Design at the Design Academy Eindhoven, where she graduated with distinction in 2008.

For her, a designer is a researcher, an engineer, a craftsman and a storyteller who tells life stories like the ones she expresses through her designs. From furniture to products and interior design, her collections reflect her methodological and professional inclination to Universal Design and the creation of products that are truly accessible to anyone. She places human beings, with all their frailties and limitations, at the centre of her ergonomic, adaptive, thoughtful and inclusive design.

She is a storyteller, a restless aesthete and a designer with nomadic inspirations. In 2010, together with Hunn Wai, she founded the multidisciplinary design studio Lanzavecchia + Wai, where she became Creative Director in 2012. The studio has offices in Pavia and Singapore.



Architect, stylist and interior designer, Elisa Ossino is a constant benchmark for contemporary design with her light and elegant touch. Her research focuses on interior design, installations, sets and image identity. Born in Sicily, she graduated from Milan Polytechnic.

In 2006 she founded Elisa Ossino Studio – her company headquarters and operations network dealing with art direction, design and styling – working with the most important interior design magazines and leading manufacturers.

Her work combines abstract geometric shapes and monochrome colours, hinting at metaphysics and surrealism, to create a consistent and evocative relationship between space, light and objects, all enhanced by her strong design.

A sense of suspension inspires Elisa's style and underlies the lightness of her every project.



TRUSSARDI CASA\_ Mekong Armchair\_2022



TRUSSARDI CASA\_ Astract Sofa\_2022



DePadova\_ Erei\_2018

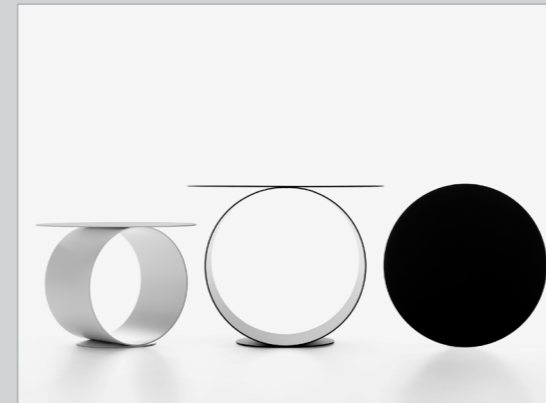

MDF ITALIA \_2019\_ Metodo



Elledecor\_2021



Alcantara Magic Forest\_Milan



Case da Abitare lists Leonardo Talarico among the top 15 under 35 Italian talents. In 2020, Milano Finanza Living included him in the Dreamers list, the new generation of up-and-coming talents that are rewriting the world of design.

He has designed projects for renowned international companies like Cappellini, Tod's, Mercedes-Benz, Alcantara, Living Divani, Mdf Italia, CC-tapis, Flaminia and Henrytimi.

His approach to projects is to greatly reduce excess, emphasising each detail and a very personal artistic trait that transcends time and temporary trends. Leonardo Talarico's products were displayed during the design weeks of Milan, Paris, Cologne, London, Moscow and New York.

The Financial Times, The Telegraph, La Repubblica, Interni, Wallpaper, Elle Decor and Para ti Deco refer to him as one of "5 under 35 designers worldwide that will improve people's lives with their projects".



## MOOD

The search for **quiet elegance** is the focus of the 2024 collection. It expresses and reinforces the brand's vision of "good design", where luxury equals elegance and objects made with care and passion that are capable of adapting to a sophisticated, "stylish" and cosmopolitan lifestyle. A lifestyle that is increasingly moving away from flamboyant luxury and the excessive use of logos.

Casa Trussardi wants to remain a "shelter", a nest and a hideaway, an intimate and private universe where there is room for the things that make us feel good and that reflect how we are and live, not how we appear. On the surface, this may seem like a snobbish attitude. In reality, it is nothing more than a strategic decision to offer an alternative to other LLG proposals.

## DESIGN

The process begins with a detailed project brief which covers everything, from market trends to catalogue requirements, from the intuition of the people working behind the scenes to the talent of the designers involved. This creative process ensures harmony, consistency and continuity throughout the collective and collaborative process of creating and producing the collection.

Comfort and functionality are at the heart of Trussardi Casa's successful products, as is the fine-tuning of proportions and sizes, which are inspired by modern lifestyles and references to the world of fashion. These are always reflected in the refined details of the furnishings.

## MATERIALS

DENIM, a material that is more fashionable than ever, is definitely one of the most innovative textile coverings this year. Trussardi Casa has used it to lend a more informal style to its products. The other is COWY, a composite material made from 50% cowhide waste, in line with Trussardi Casa's commitment to environmental protection.

While the matte finish remains the most important finish for both the new Travertino Romano Light and Grey Frisé veneer, it is illuminated by brighter accents of lacquered glass, enamelled copper and Nichel Light lacquer.

The focus on the tactile and sensory quality of the materials continues with the concrete effect of the new Light Cream Concrete and the soft touch of metallic paints.

**BLOOMS Sofa (Francesca Lanzavecchia)**

**MONO Armchair (Leonardo Talarico)**

**NEBULINA Chair (Francesca Lanzavecchia)**

**NEBULINA Lounge Chair (Francesca Lanzavecchia)**

**TOWN Cabinet / TV Cabinet (Jimmy Delatour)**

**ZERO Side Table (Leonardo Talarico)**

**HUG Side Table (Silvio Pompei)**

## **NEW PRODUCTS**

# BLOOMS Sofa

• MOOD

QUIET ELEGANCE: The design must be the best possible expression of this idea. It means elegance, care and a passion for detail and craftsmanship, as well as versatility and flexibility of form and content. A sofa to be used in harmony with the lifestyle of a Trussardi Casa customer: demanding, refined, cosmopolitan and “stylish”, far removed from the flamboyant luxury of logos and brands that are easy to recognise and copy.

• CONCEPT

- HIGH BACKREST
- HIGH LEVEL OF COMFORT, SOFTNESS AND SUPPORT
- NO REMOVABLE BACK CUSHIONS
- SINGLE SEAT CUSHION
- INVISIBLE FEET



• FASHION

LAPEL NECK: an essential fashion feature of increasingly oversized outerwear that protects, envelops and hugs the body inside oversized coats and jackets: this is a must-have feature for the most contemporary looks. Combined with a soft and tactile texture, and enhanced by quilted details, this becomes an inspiration for the world of design. Once again, design and fashion come together to create a unique and original product.



## BLOOMS Sofa

- **DESIGN**

- OUTSTANDING FEATURES: The backrest/armrest block rests on the frame and wraps around it like the collar of an overcoat, fully in line with the design brief.

- DETAIL: to further enhance a sense of softness, the backrest/armrest block has been padded and quilted like a real garment. The PALI quilt design, inspired by the same Trussardi bag, has been revisited in terms of size and proportions.

- **MATERIALS**

- PADDING: the backrest/armrest block is filled with feather and Fiberfill, ensuring a high level of comfort. In addition, the fabric is coupled with a thick layer of Dacron, which enhances the size and softness of the PALI quilted design. It should be noted that this design can only be used on certain fabrics and not on leather (refer to the price list for upholstery usage restrictions).

- PAIRED MATERIALS: The very structure of the sofa, consisting of a frame, a seat cushion and a back-armrest element, allows different materials, textures and colours to be combined together. This creates unusual combinations for the home, such as denim paired with leather.

- **FOCUS POINT**

- COMFORT: the tall backrest is cushioned for comfort and offers ample back support, while the “crumpled” effect of the feather filling reduces the visual impact of the sofa, making it appear less tall than it actually is.

- DIMENSIONS: the sofa is not very deep and has a thin armrest, which provides ample seating space. The quilted feature that also runs around the back of the sofa makes Bloom an ideal centrepiece for any room.



**BLOOMS** Sofa

Design: Francesca Lanzavecchia



## MONO Armchair

- **DESIGN**

- OUTSTANDING FEATURES: the designer's style is very accurate and essential.

- DETAIL: a single-block frame is created by a cylindrical sculptural shape.

- **MATERIALS**

- FRAME: available in two wood veneers, both with a matte finish: black-stained ribbed ash or Grey Frisé.

- PAIRED MATERIALS: the upholstered seat and backrest provide comfort and allow for the use of various materials in terms of composition, texture and colour, resulting in a unique and customised product.

- **FOCUS POINT**

- STYLE: original yet unobtrusive, subtle yet striking. Ideal for a variety of environments and uses.

- DIMENSIONS: small dimensions emphasise Mono's versatility.



### FRAME

BLACK-STAINED RIBBED  
ASH WITH A MATTE  
FINISH



GREY FRISÉ WITH A  
MATTE FINISH

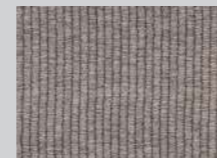

## NEBULINA Chair / Lounge Chair

- **DESIGN**

- SILHOUETTE: Nebulina is a new version of the Nebula collection. The backrest seamlessly integrates with the back legs, with rounded contours and slightly curved shapes that achieve a perfect balance between design and ergonomics.

- DETAIL: the gunmetal chrome-plated zip serves a double purpose: technical, because its positioning makes the upholstery process easier, and aesthetic, because it enhances the profile of the backrest.

- **MATERIALS**

- FRAME: foamed polyurethane ensures precise and accurate profiles and lines. It also makes the product lightweight.

- UPHOLSTERY: slightly stretchy fabrics and leather, whether natural or recycled, are strongly recommended. (refer to the price list for upholstery usage restrictions).

- **FOCUS POINT**

- STYLE: original yet unobtrusive, subtle yet striking.

- DIMENSIONS: generously sized to enhance the pleasure of a comfortable sitting experience.

NEBULINA LOUNGE CHAIR



NEBULINA CHAIR



**NEBULINA** Chair / Lounge Chair

Design: Francesca Lanzavecchia





## TOWN Cabinet and TV Cabinet

- **DESIGN**

- SIZE: the purity of its design is highlighted by a harmonious asymmetry that produces an unusually balanced arrangement.

- DETAIL: the base seems to perforate the container and unexpectedly resurfaces with an inlay on the cabinet top, which continues to extend upwards through practical twin trays.

- **MATERIALS**

- FRAME: the new wood veneer, romantically named Grey Frisé, has a matte finish and a wavy-looking surface that complements the black-stained ribbed ash of the base and trays.

- **FOCUS POINT**

-STYLE: the product is functional and may seem simple at first glance. However, its unique features such as the inlay of the top and the two movable trays, make it truly special.

### BASE / INLAY / TRAY

BLACK-STAINED RIBBED  
ASH WITH A MATTE  
FINISH



### CABINET

GREY FRISÉ WITH A  
MATTE FINISH

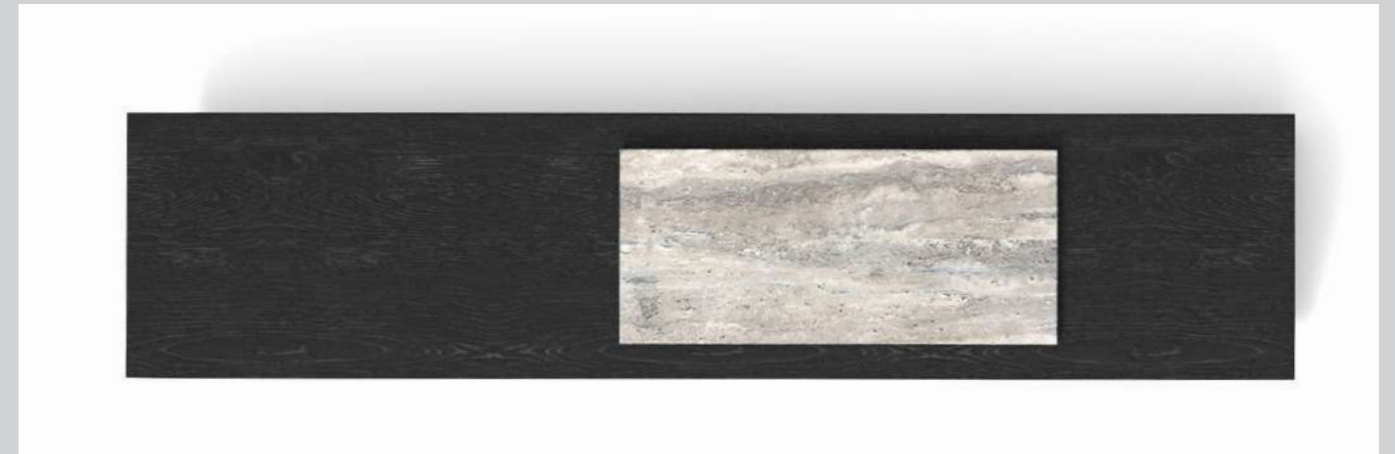

# ZERO Side Table

## • DESIGN

- OUTSTANDING FEATURES: the designer's style is very accurate and essential.

- DETAIL: the design consists of a simple cylindrical shape that supports two tabletops stacked on top of each other in a staggered arrangement.

## • MATERIALS

- FRAME: matte painted metal with a soft touch effect available in two colours.

- PAIRED MATERIALS: the contrast between the matte finish of the metal part (base + tabletop) and the lacquered smokey grey satin-finished glass or enamelled copper, creates unique translucent effects and ever-changing iridescent colours.

## • FOCUS POINT

- DIMENSIONS: the tables are deliberately small so that they can be used as side tables, and are easy to move around. They can be used separately or together, or in combination with other side tables from the same collection.

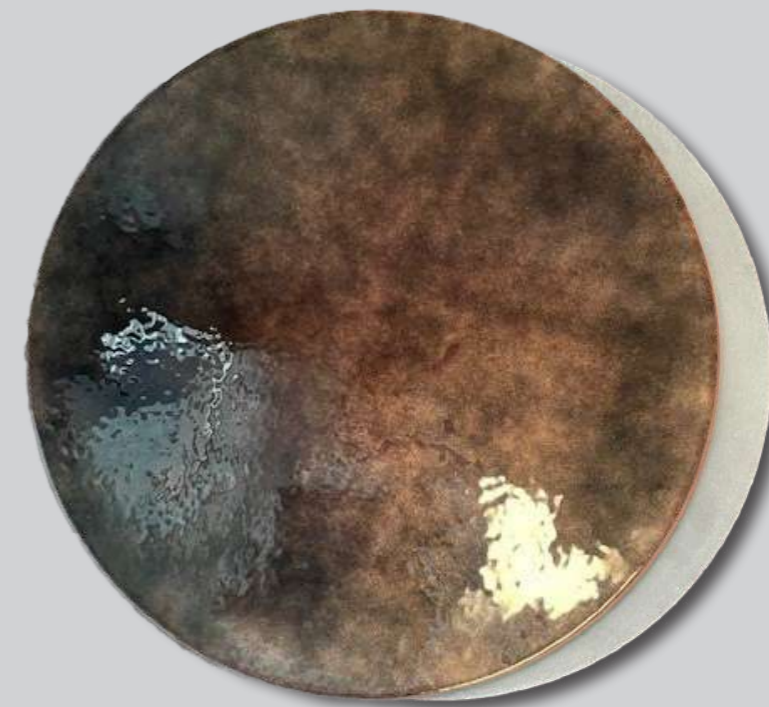

### BASE + TOP

REDBLACK METAL



GREYBLACK METAL



### OVERLAY TOP

LACQUERED GLASS  
REDBLACK



LACQUERED GLASS  
GREYBLACK

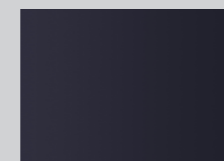

REDGREY ENAMELLED  
COPPER



## HUG Side Table



- **DESIGN**

- OUTSTANDING FEATURES: the leather-covered thin metal sheet wraps around itself, surrounding the table top as if in an embrace.

- DETAIL: metal “buttons” decorated with the Trussardi logo fasten the metal sheet like a shirt cuff. A subtle and non-clichéd reference to clothing.

- **MATERIALS**

- LEATHER: the decision to use this material as the only option, was a deliberate choice, intended to enhance the shape of the product and lend it a sense of luxury and sophistication.

- **FOCUS POINT**

- DIMENSIONS: the tables are deliberately small so that they can be used as side tables, and are easy to move around. They can be used separately or together, or in combination with other side tables from the same collection.



NELI Coffee Table (Matteo Agati)

NELI Wall Shelf (Matteo Agati)

GODWIN Bed (Carlo Colombo)

NEBULA Dormeuse (Francesca Lanzavecchia)

## ADDITIONAL PRODUCTS

## NELI Coffee Table

### • DESIGN

- OUTSTANDING FEATURES: two perpendicular T-shaped legs are the distinctive feature of this table. They support the table top, its frame and rounded edges. The same concept underlies the NELI console tables presented at last year's Salone.

- DETAIL: the sinuous line of the structure, enhanced by a refined curved design, is connected to the frame that holds the top, giving the product a sense of movement.

### • MATERIALS

- FRAME: the solid wood frame, with moulded and bevelled edges, and the interlocking joints that are visible to the eye, add to the quality of a product that has been crafted to the highest standards.

- PAIRED MATERIALS: the frame is made from black-stained ribbed ash with a matte finish. It can be paired with either a leather-covered top or a new veneer, romantically named Grey Frisé, which has a wavy-looking surface and a matte finish.

### • FOCUS POINT

- DIMENSIONS: designed to be small enough to fit in homes with limited space. Available in three different sizes. They can be used separately or in combination.

#### FRAME

BLACK-STAINED ASH WITH  
A MATTE FINISH



#### TOP

GREY FRISÉ WITH  
A MATTE FINISH



LEATHER



## NELI Wall Shelf

### • DESIGN

- OUTSTANDING FEATURES: it is not a modular bookcase, but a shelf available in two different sizes, which can be used separately or in different combinations.

- DETAIL: the sinuous line of the structure maintains its aesthetic consistency even when used as a single unit, and is enhanced when arranged into multiple modular compositions.

### • MATERIALS

- FRAME: the solid wood frame, with moulded and bevelled edges, and the interlocking joints that are visible to the eye, add to the quality of a product that has been crafted to the highest standards.

- PAIRED MATERIALS: the frame is made of black-stained ribbed ash with a matte finish, and can be further enhanced by a leather-covered shelf.

### • FOCUS POINT

- STRIKING DESIGN: the product has a distinctive and powerful design that defines the space with very few elements. This is why it is referred to as a shelf rather than a bookcase.

#### FRAME

SOLID WOOD AND BLACK-STAINED ASH VENEER WITH A MATTE FINISH

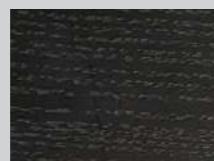

#### COVER

LEATHER

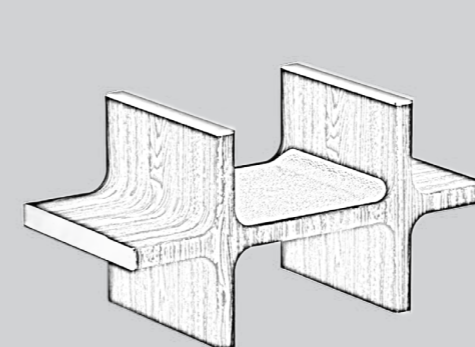
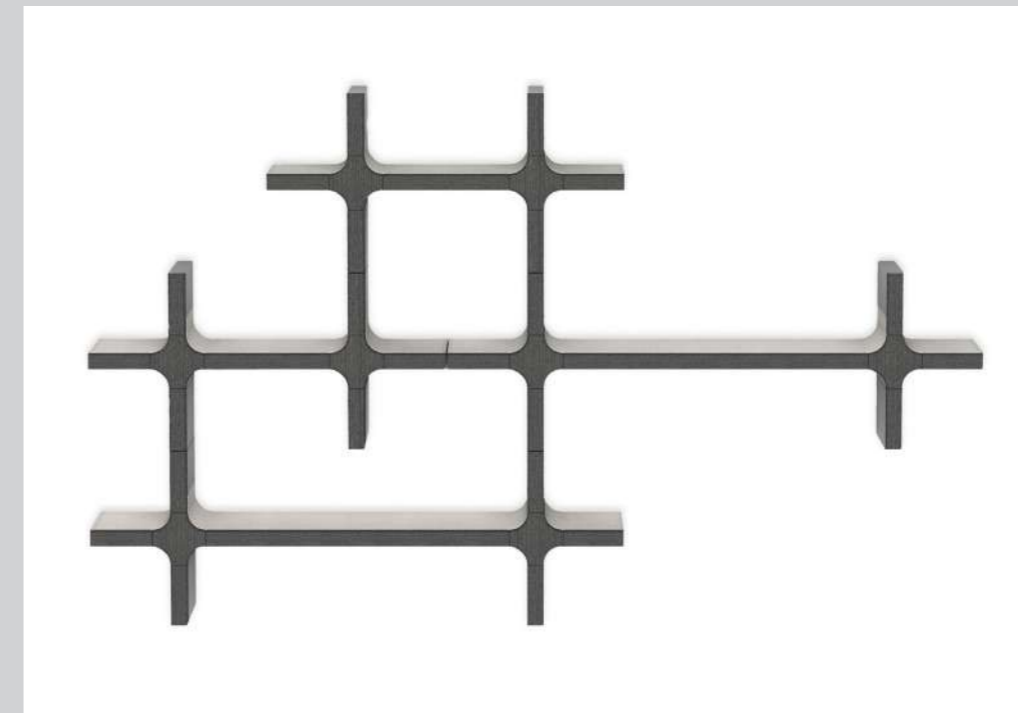
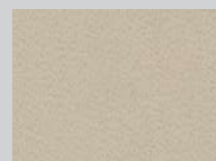

SMALL

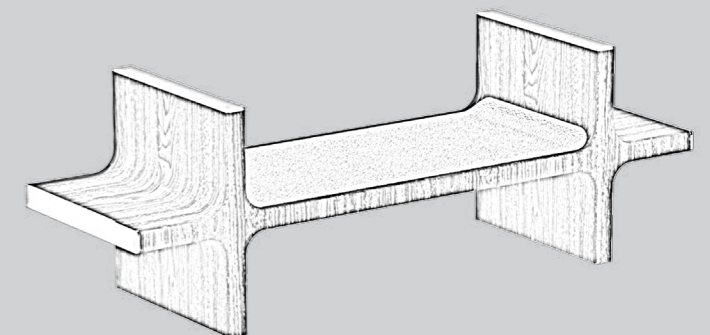

MEDIUM

## GODWIN Bed

### • DESIGN

- OUTSTANDING FEATURES: the upholstered detail, enhanced by a flat fell seam (inspired by Trussardi's outerwear collections) is a clear and distinctive feature that runs around the entire perimeter of the base and headboard.

- DETAIL: the sculptural size of the headboard is softened by a clean cut, which creates a sense of movement on the surface through a play of light and shadow.

### • MATERIALS

- PAIRED MATERIALS: the upholstered detail, enhanced by a flat fell seam, separates the surfaces, allowing for the creation of a customised product by combining different materials and colours.

### • FOCUS POINT

- OPTIONAL FEATURES: this first bed in the Trussard Casa collection with a headboard that can be fitted with two side PANELS and two bedside tables. Godwin's dynamic composition makes the bed the undisputed centrepiece of the bedroom, meeting both the most basic needs and the highest aesthetic requirements.



### TOP

RIBBED ASH WOOD  
BLACK-STAINED WITH A  
MATTE FINISH

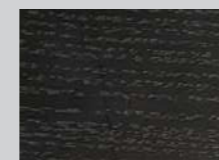

LEATHER

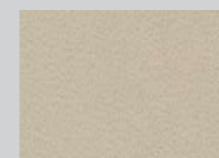

## NEBULA Dormeuse

### • DESIGN

- OUTSTANDING FEATURES: a new product has been added to the large NEBULA range. It can be used on its own, in combination with other pieces from the same range or with other products from the collection.

- DETAIL: the backrest/armrest design is unique. It surrounds the curved seat, starting as a high backrest and then lowering to become an armrest. Lanzavecchia's design is characterised by smooth and graceful curved lines, and this product is a perfect example.

### • MATERIALS

- PIPING: A thick piping runs along the perimeter to enhance the silhouette of the armchair and soften its edges.

- PAIRED MATERIALS: the shapes enable combining different materials together in terms of composition, texture and colour.

### • FOCUS POINT

- VERSATILITY: a product with a distinctive character that can stand alone or complement other items in the collection, while always remaining a prominent feature!

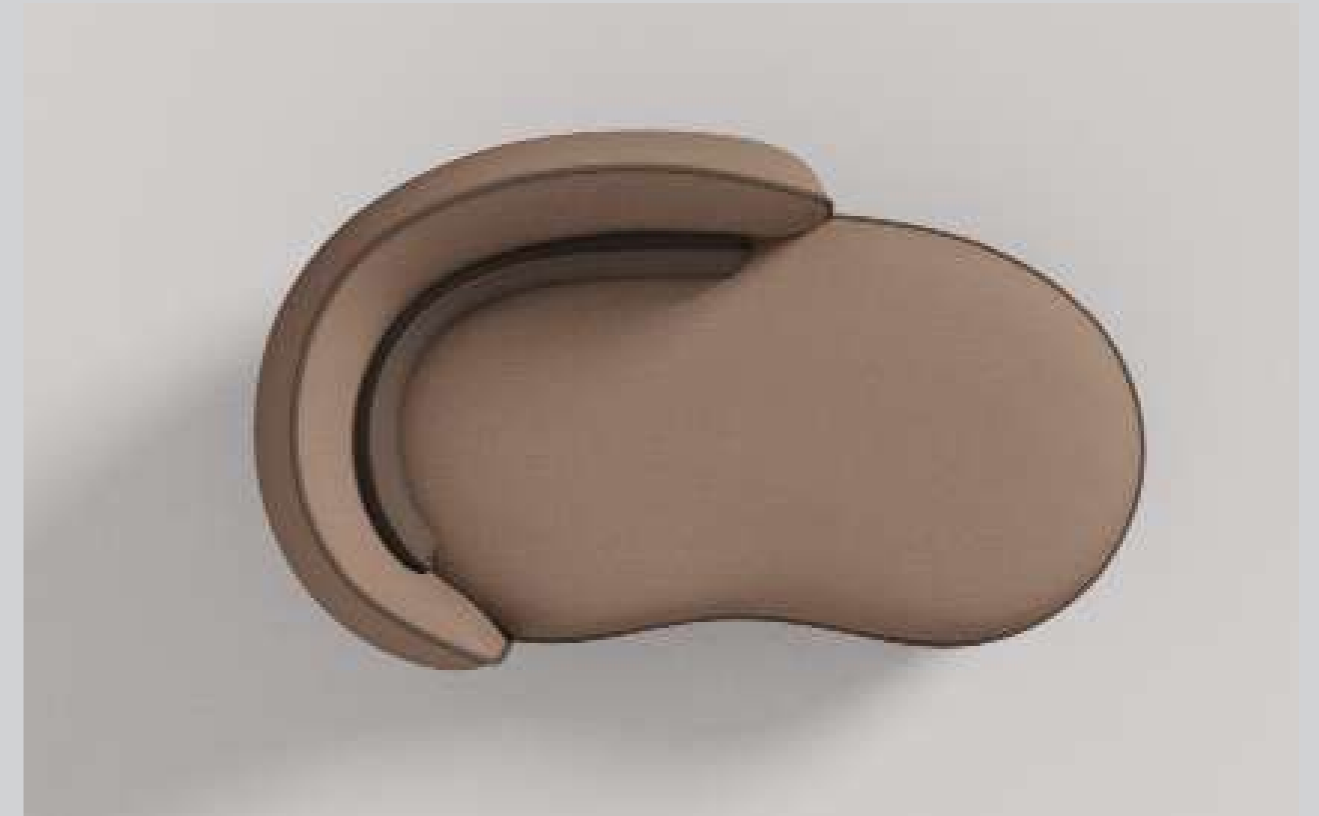





**RUGS AND  
DECORATIVE  
CUSHIONS**

# CAMOUFLAGE



## CAMOUFLAGE ROUND

- dia. 200 (TPT29)
- dia. 250 (TPT30)
- dia. 320 (TPT31)

## CAMOUFLAGE RECTANGULAR

- 300x200 (TPT32)

## CAMOUFLAGE SQUARE

- 300x300 (TPT34)



CREAM



TITANIUM



SMOKE

# NODE

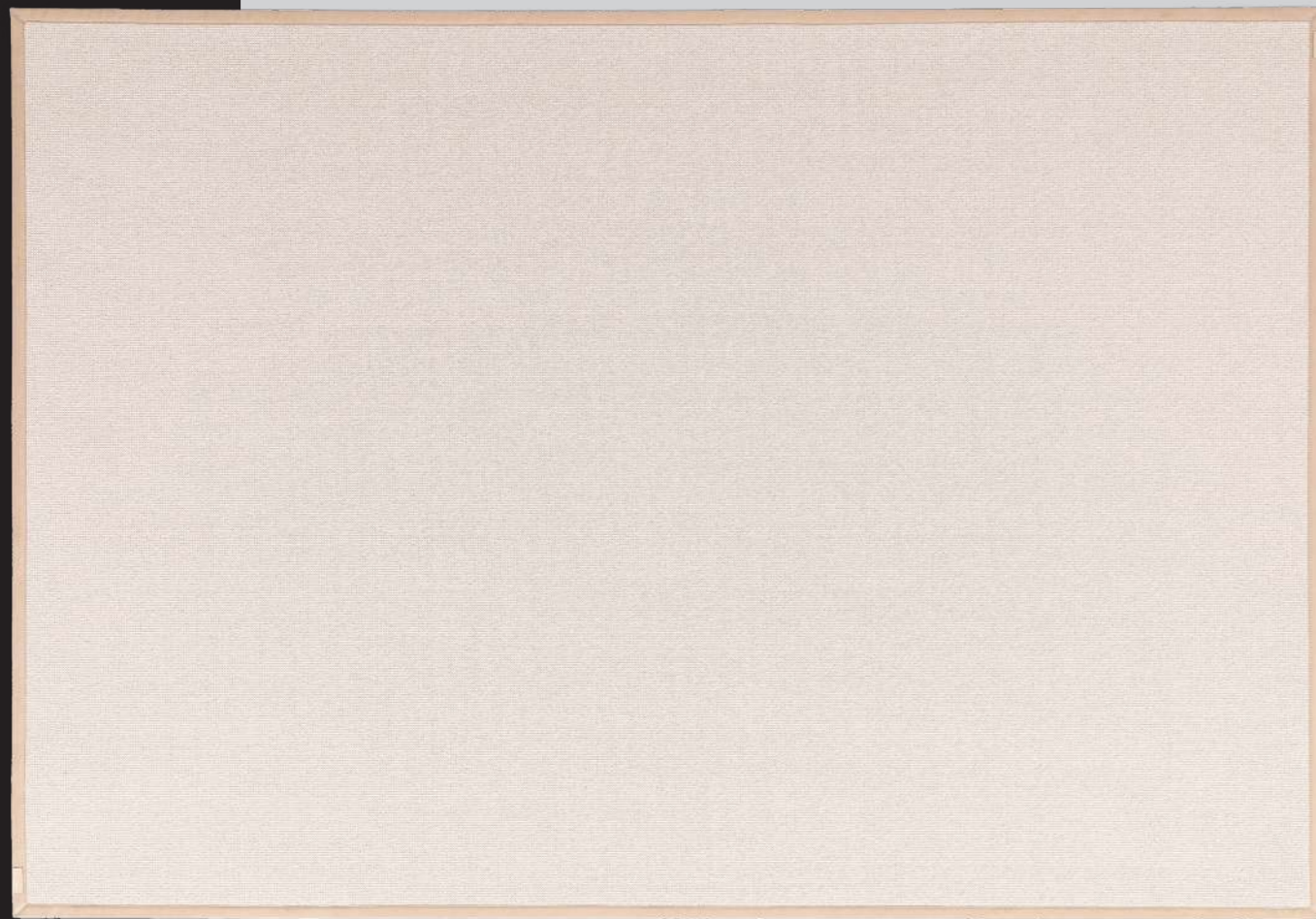

NODE TEXTURE

## NODE

360x250 (TPT37) NATURAL

# CURVY

## CURVY OVAL

360x270 (TPT36)

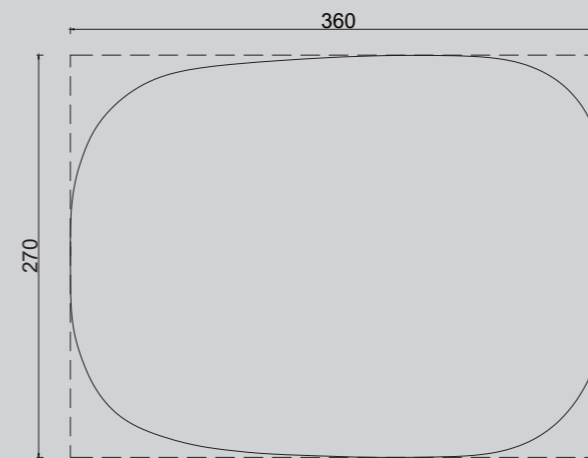

NATURAL

## CURVY ROUND

235x250 (TPT35)

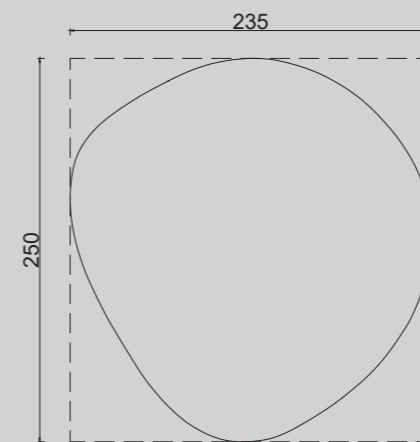

SMOKE

**TCS43/50** 50x50 - PALI embroidery tone-on-tone



DENIM



COWY



SKIN



ARTAX - APLOMB - AIACE

N.B. also available in leather  
(NUVOLA - MAINE - VELVET)

**TCS42/30** 40x30 - CIRCLE embroidery white

**TCS42/40** 40x40 - CIRCLE embroidery white



DENIM



COWY



SKIN

N.B. also available in leather  
(NUVOLA - MAINE - VELVET)



## FINISHES

## “Circle Jacquard”



A reinterpretation of the traditional “circle” pattern in a two-colour fabric. The Jacquard technique is used to produce sharp lines and make the decorative pattern more prominent.



CIRCLE JAQUARD 3F 001 NATURAL/BLACK



CIRCLE JAQUARD 3F 002 MOKA/BLACK



## “Cowy”

### • COMPOSITION

COWY is an innovative and environmentally friendly product made from waste and/or surplus materials that would otherwise be discarded, rather than from slaughtered animals.

The material is made of 50% leather waste combined with other materials such as polyester and polyurethane.

### • TECHNICAL SPECIFICATIONS

It is referred to as a composite material with a very high degree of mechanical efficiency. This is achieved by combining different materials in such a way that their properties complement each other, with no technical drawbacks. Its special and exclusive formula is what makes it a truly high-performance material.

COWY has excellent resistance to tearing, abrasion and bending. It is flame retardant and has a high degree of colour fastness to light.

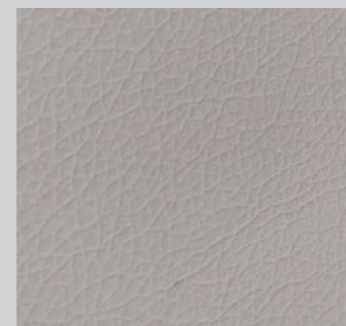

### FINISH

It has a slightly cloudy effect that is pleasant to touch and look at, giving it movement and depth.

### • PRODUCT CARE

Easy to clean. Wipe gently with a soft damp cloth (avoid abrasive cleaners, solvents or chemical cleaners of any sort).



### • FOCUS POINT

COWY represents a perfect combination of innovation, research, product optimisation and technical performance, while respecting the planet.



SAVE THE NATURE

“Plain”



CARACAS 1F 007 IVORY



CARACAS 1F 009 MAUVE



CARACAS 1F 008 SMOKE



FLORENCE 1F 001 IVORY



FLORENCE 1F 002 QUARTZ GREY



FLORENCE 1F 003 SAND

“Bouclé 1”



LANDSCAPE 2F 003 NATURAL



LANDSCAPE 2F 004 SILVER



LANDSCAPE 2F 005 MAUVE

“Structure 1”



KARMA 2F 001 NATURAL



KARMA 2F 004 SMOKE



KARMA 2F 005 MAUVE



CRUISE 1F 002 SAND



CRUISE 1F 003 MOKA



“Thecnical”



COWY 1F 001 OATS

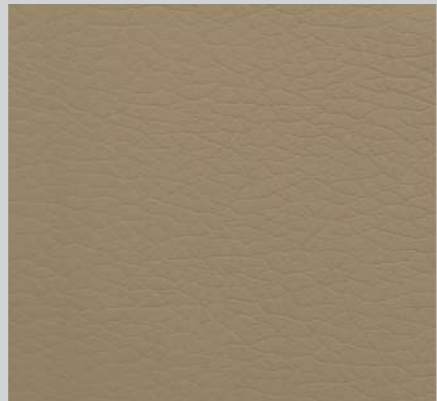

COWY 1F 003 POWDER

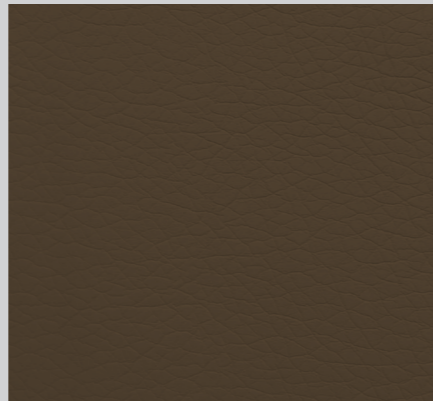

COWY 1F 004 PRALINE

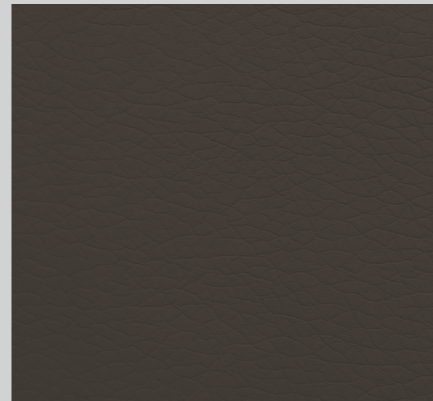

COWY 1F 005 MOKA

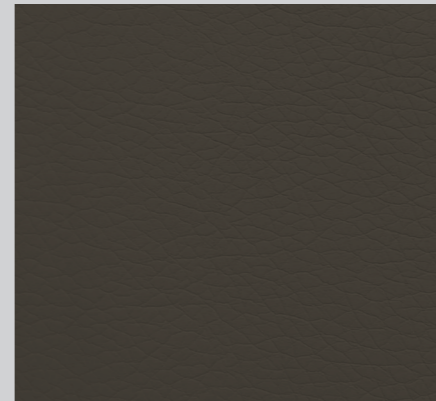

COWY 1F 006 SLATE



SKIN 2F 001 NATURAL



SKIN 2F 002 TAUPE



SKIN 2F 003 TOBACCO



SKIN 2F 00004 COOKIE



SKIN 2F 005 MUD



SKIN 2F 006 MAUVE

“Texture”



HORIZONT 1F 001 SAND



HORIZONT 1F 002 POWDER



CARACAS 1F 003 SMOKE

“Special”



DENIM 2F 001 DARK BLU

Wood finish



MATT GREY FRISE

Marbles



MATT TRAVERTINO ROMANO

Special finish

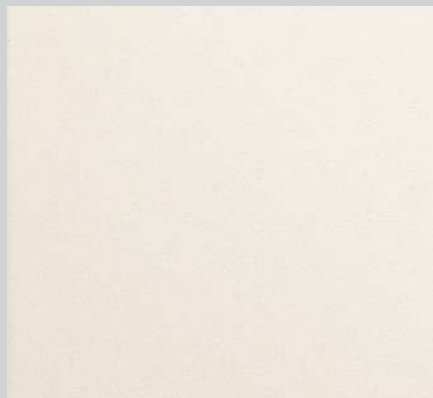

NICHEL LIGHT



LIGHT CREAM CONCRETE

# TRUSSARDI

CASA

Produced & distributed by  
Club House Italia Spa  
Via Balzella 56, 47122 Forlì, Italy  
T +39 0543 791911

Headquarters  
Palazzo Orsi Mangelli  
C.so Diaz 43/45, 47121 Forlì, Italy  
info@luxurylivinggroup.com

[luxurylivinggroup.com](http://luxurylivinggroup.com)

V1 06/2023